

До: „АЕЦ Козлодуй“ ЕАД
гр. Козлодуй 3321

Относно: пазарни консултации № 51894 с предмет „Доставка на трифазен измерител и калибратор“

На вниманието на:

Г-н Христо Пачев

Гл. експерт „Маркетинг“

Тел.: +359 973 7 6140

ИНДИКАТИВНО ПРЕДЛОЖЕНИЕ по проведени пазарни консултации № 51894 за „Доставка на трифазен измерител и калибратор“

ОТ

„МВ КОРПОРЕЙШЪН“ ЕООД

ЕИК: 206475290; ИН по ДДС: BG206475290

седалище и адрес за кореспонденция: гр. София 1612, ж.к.: Лагера“, бл. 52, вх. Г, ет. 5

лице за контакт: инж. Марианна Витанова – Управител, тел.: 0896976769

Уважаема г-н Пачев,

Имаме удоволствието да Ви предложим нашето индикативно предложение по гореспоменатата пазарна консултация № 51894:

№.	ИД по ВААН	Наименование	Технически характеристики	Мярка	Количество	Стандарт, нормативен документ, каталожен номер и др.	Производител	Ед. цена без ДДС лв.	Ст-ст Без ДДС лв.
1.	-	Калибратор трифазен Модел: TS33 C0.1	Трифазен измерител и калибратор. Клас на точност: 0.1 Измервани величини: напрежение (0,05-600V); ток (0,01-120A); честота (40-70Hz); фазова разлика (-180÷+180°); Задавани величини: напрежение: (20-600V);	Бр.	1	ISO9001:2015 ISO17025	Calmet sp.z o.o.	48 300.00	48 300.00

			ток (0,02-120A); честота (45-65Hz); фазова разлика (-180÷+180°); Допълнителни аксесоари: Софтуер за връзка с компютър през USB със съответните кабели; Силови кабели до 120A и накрайници; Разширителен комплект кабелни накрайници.						
--	--	--	---	--	--	--	--	--	--

Търговски условия:

1. Посочената цена е в лева, без ДДС.
2. Срок на доставка: до 90 дни.
3. Гаранционен срок: 12 месеца.
4. Условия на доставка: DDP гр. Козлодуй.
5. Начин на плащане: до 30 дни.
6. Валидност на офертата: 30 дни.

Списък на съпровождащите стоката документи:

1. Сертификат за калибрация.
2. Инструкция за експлоатация.
3. Гаранционна карта.
4. Приемо-предавателен протокол.
5. Оригинална данъчна фактура.

Дата: 26.07.2023 г.
гр. София

С уважение:
Марианна Витанова - Управител

Three-phase Fully Automatic Test System with Reference Standard and Integrated Current and Voltage Source

Calmet TS33

- Easy verification of meters under precise load conditions, using integrated current and voltage source
- Automatic operation with predefined load points without the need of an external PC
- Modern SD flash memory card up to 32GB for storage of customer data and measurement results
- Display of vector diagram, phase sequence, wave form oscilloscope, harmonics spectrum bar and trend charts for analysis of the mains conditions
- User-friendly system for data input and operation of combined source and reference meter
- The system may be used either as a stand-alone reference standard meter class 0.02, 0.04 or 0.1, or together with the integrated power source, or as a stand-alone three-phase power calibrator class 0.1
- Data readout and test system control via USB, Ethernet and Bluetooth



The Calmet TS33 portable test system consists of a three-phase reference meter of accuracy class 0.02% (or 0.04% or 0.1%) and an integrated three-phase current and voltage source up to 3x120A/600V. The TS33 is designed for analysis of complete metering installations and local mains conditions.



The Calmet TS33 Automatic Test System is used for:

- testing of electricity meters according to EN 50470, IEC 62052 and IEC 62053 directly on site including measure of meter error, counter error and maximum power meter error,
- verification of power network wiring with measure and recording of power network parameters,
- testing of Current Transformers (CT) and Potential Transformers (PT) according to EN 60044 directly on site including measure of CT/PT Ratio error and phase error as well as CT/PT burden measurement simultaneously in three phases,
- measuring of power quality parameters.

Examples of applications

The use of TS33 as a stand-alone reference meter for electricity meter testing

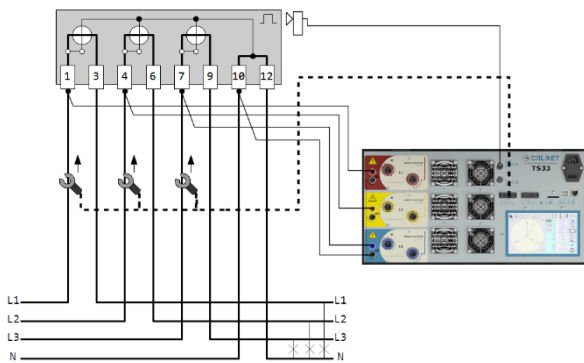

The use of TS33 as a stand-alone reference meter for Current Transformer testing

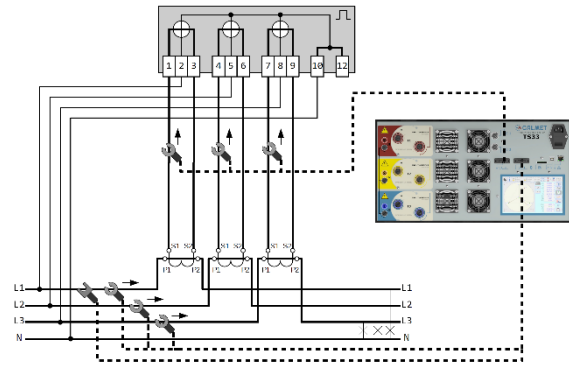

The use of TS33 as a reference meter together with the integrated power source for electricity meter testing

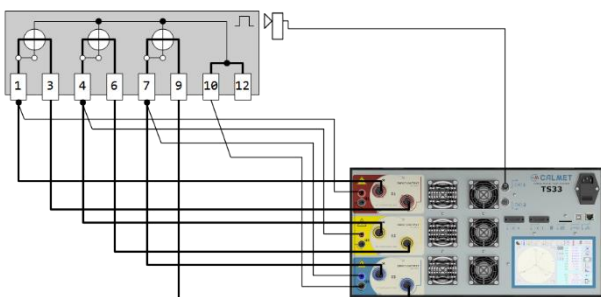

The use of TS33 as a voltage meter and three phase current source for electricity meter testing

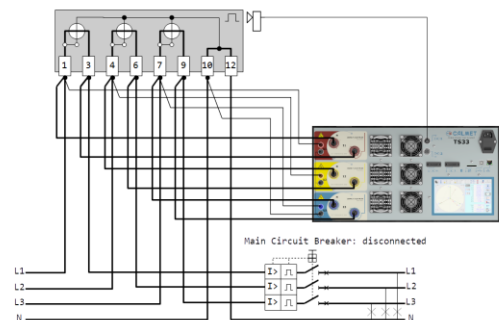

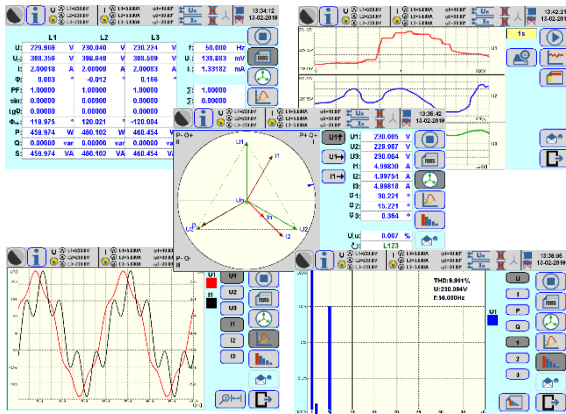

Color Touchscreen for easy operation enables:

- measurement of power network parameters: voltages U1, U2, U3, U12, U23, U13, UN, currents I1, I2, I3, IN, frequency f, phase angles $\varphi_1, \varphi_2, \varphi_3$, power factors PF1, PF2, PF3, Σ PF, factors $\sin\varphi_1, \sin\varphi_2, \sin\varphi_3, \Sigma\sin\varphi, \tan\varphi_1, \tan\varphi_2, \tan\varphi_3, \Sigma\tan\varphi$, angles between voltages $\angle U12, \angle U13$, powers P1, P2, P3, Σ P, Q1, Q2, Q3, Σ Q, S1, S2, S3, Σ S,
- visualization of measurement results in form of: table, vectors, trend chart, oscilloscope (waveform) or bar chart (harmonics of U, I, P, Q).

Specifications for the power network parameters

Parameter	Range	Accuracy ¹⁾²⁾³⁾⁴⁾		
		class 0.02	class 0.04	class 0.1
Voltage (Direct)	0.05...600V	$\pm 0.02\%$ ⁵⁾	$\pm 0.04\%$ ⁵⁾	$\pm 0.1\%$ ⁵⁾
Voltage (VoltLiteWire 40kV)	0.1...40kV	$\pm 0.1\% \pm Em$		
Current (Direct)	0.01...120A 0.001...0.01A	$\pm 0.02\%$ $\pm 0.02\%*$	$\pm 0.04\%$ $\pm 0.04%*$	$\pm 0.1\%$ $\pm 0.1%*$
Current (Clamps CT10AC)	0.1...12A 0.003...0.1A	$\pm 0.2\%$ $\pm 0.2%*$		
Current (Clamps CT100AC)	0.1...120A 0.01...0.1A	$\pm 0.2\%$ $\pm 0.2%*$		
Current (Clamps CT1000AC)	10...1200A 0.3...10A	$\pm 0.2\%$ $\pm 0.2%*$		
Current (Flexible Clamps FCT3000AC)	0.3...30A/3...300A/30...3000A	$\pm 0.1\% \pm Em$		
Current (AmpLiteWire 2000A)	1...2000A	$\pm 0.1\% \pm Em$		
Power and energy (Direct)	0.01...120A / 10...600V 0.001...0.01A / 10...600V	$\pm 0.02\%$ $\pm 0.02%*$	$\pm 0.04\%$ $\pm 0.04%*$	$\pm 0.1\%$ $\pm 0.1%*$
Power and energy (Clamps CT10AC)	0.1...12A / 10...600V 0.01...0.1A / 10...600V	$\pm 0.2\%$ $\pm 0.2%*$		
Power and energy (Clamps CT100AC)	0.1...120A / 10...600V 0.01...0.1A / 10...600V	$\pm 0.2\%$ $\pm 0.2%*$		
Power and energy (Clamps CT1000AC)	10...1200A / 10...600V 1...10A / 10...600V	$\pm 0.2\%$ $\pm 0.2%*$		
Power and energy (Flexible Clamps FCT3000AC.B)	0.3...30A/3...300A/30...3000A / 10...600V	$\pm 0.1\% \pm Em$		
Power and energy (VoltLiteWire 40kV + AmpLiteWire 2000A)	1...2000A / 0.5...40kV	$\pm 0.1\% \pm Em$		
Frequency	40...70Hz	$\pm 0.003\text{Hz}$		
Phase shift (Direct)	-180...+180°	$\pm 0.01^\circ$ ⁵⁾⁶⁾	$\pm 0.02^\circ$ ⁵⁾⁶⁾	$\pm 0.04^\circ$ ⁵⁾⁶⁾
Phase shift (Clamps)	-180...+180°	$\pm 0.1^\circ$ ⁵⁾⁷⁾		
Power factor $\cos\varphi$ and $\sin\varphi$	0...±1	± 0.001 ⁵⁾⁶⁾⁷⁾		
Voltage and current - temperature coefficient (Direct)	0.001% per 1°C in range -10...+50°C			
Time stability (for Energy Direct)	Short term [1h] = 0.01%, long term [1 year] = 0.03%			
Power short term [1h] stability (Direct)			$\pm 0.005\%$	$\pm 0.010\%$
Power long term [1 year] stability (Direct)			$\pm 0.010\%$	$\pm 0.025\%$
Power temperature coefficient per 1°C (Direct)			$\pm 0.001\%$	$\pm 0.002\%$

- 1) % - related to the measuring value, %* - related to the measuring range final value (is underlined)
- 2) absolute extended uncertainty under confidence level of 95% covers reference uncertainty of standards, stability in 12 months, influence quantities (ambient temperature +20...+26°C, humidity and power supply voltage 85...265V, frequency 47...63Hz)
- 3) Em - sensor basic error, $Em = 1\% + 0.1\%*$ (Flexible Clamps FCT3000AC), $Em = 2\% + 0.2\%*$ (VoltLiteWire 40kV and AmpLiteWire 2000A)
- 4) power and energy errors related to apparent power
- 5) in voltage range 10...600V (Direct)
- 6) in current range 0.01...120A (Direct)
- 7) in current range: 0.1A...12A (Clamps CT10AC), 0.1A...120A (Clamps CT100AC), 10A...1200A (Clamps CT1000AC)

Specifications for the power quality parameters

Parameter	Range	Accuracy ¹⁾
Harmonics in voltages, currents, P and Q powers	amplitude	0...100% of input
	phase	-180...+180°
Total harmonic distortion THD in voltages and currents	0...100% of input	1 st ...63 rd
Total interharmonic distortion TID in voltages and currents	0...15% of input	40...3200Hz
Signal voltage ⁵⁾	0...15% of input	40...3200Hz
Voltage asymmetry	0...100%	$\pm 2\%$

- 1) absolute extended uncertainty under confidence level of 95% covers reference uncertainty of standards, stability in 12 months, influence quantities (ambient temperature +20...+26°C, humidity and power supply voltage 85...265V, frequency 47...63Hz)
- 2) of input for 80-140Hz frequency range of harmonics with linear rise to 0.4% of input for 3200Hz
- 3) for 80-140Hz frequency range of harmonics with linear rise to 8° for 3200Hz
- 4) of input for 80-140Hz frequency range of interharmonics with linear rise to 5% of input for 3200Hz
- 5) the highest non-harmonic amplitude and frequency

The TS33 power calibrator can work in two modes:

- voltage and current source,
- current source synchronized with input voltage.

The TS33 power calibrator operates in symmetric and asymmetric circuit of connection and enables setting of:

- voltages U1, U2, U3, U12, U32, U13 (in voltage and current source mode),
- currents I1, I2, I3,
- frequency f (in voltage and current source mode),
- phase angles $\varphi_1, \varphi_2, \varphi_3$,
- power factors PF1, PF2, PF3,
- factors $\sin\varphi_1, \sin\varphi_2, \sin\varphi_3$,
- angles between voltages $\angle U_{12}, \angle U_{13}$ (in voltage and current source mode),
- maximum allowed values of voltages and currents,
- wave shape of output signals with using harmonics and predefined shape functions.

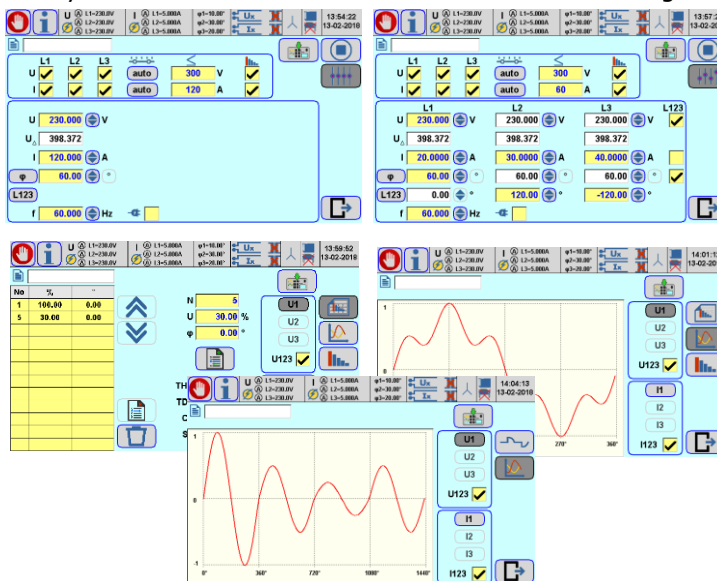

Specification for the sinusoidal signals					
Parameter	Range	Settings span	Resolution	Accuracy ¹⁾²⁾	Maximum load
Voltage U	150V	20...150V	0.001V	$\pm 0.1\%$ ⁴⁾	200mA@150V
	300V	150...300V	0.01V		100mA@300V
	600V	300...600V	0.01V		50mA@600V
Voltage short term [10min] stability				$\pm 0.01\%$	
Voltage short term [1h] stability				$\pm 0.03\%$	
Voltage distortion factor				$< 0.5\%$	
Current I	0.12A	0.02...0.12A 0.001...0.02	0.00001A	$\pm 0.1\%$ ³⁾ $\pm 0.1\%*$ ³⁾	3V@0.12A
	1A	0.12A...1A	0.00001A		12V@1A
	12A	1...12A	0.0001A		5.0V@12A
	120A	12...120A	0.001A		0.65V@60A 0.5V@120A
Current short term [10min] stability				$\pm 0.01\%$	
Current short term [1h] stability				$\pm 0.03\%$	
Current distortion factor				$< 0.5\%$ ⁵⁾	
Frequency f		45...65Hz	0.001Hz	$\pm 0.003\text{Hz}$ ⁴⁾	
Phase shift φ		-180...+180°	0.001°	$\pm 0.10^\circ$ ⁴⁾	
Phase shift short term [10min] stability				$\pm 0.05^\circ$ ⁴⁾	

¹⁾ absolute extended uncertainty under confidence level of 95% covers reference uncertainty of standards, stability in 12 months, influence quantities (ambient temperature +20...+26°C, humidity and power supply voltage 85...265V, frequency 47...63Hz)
²⁾ % - related to the setting value, %* - related to the setting span final value (is underlined)
³⁾ for Current source mode, Current is synchronized to input voltage: voltage range 20...600V, frequency range 45...65Hz
⁴⁾ not applicable for current source synchronized with input voltage mode
⁵⁾ in current range 0.02...120A

Specification for the nonsinusoidal signals				
Parameter		Settings span	Resolution	Conditions
Harmonics	amplitude	0...50% output value ¹⁾	0.1%	up to 40 th or 2000Hz
	phase	-180...+180°	0.1°	

¹⁾ 50% of output value for frequency range of harmonics to 500Hz with linear decrease to 10% of output value for 2000Hz

Testing of electricity meters (EM) directly on site may be realized in different situations:

- voltage and current circuits of the EM are powered from power net – in this case the TS33 is used as a reference meter in manual operation mode,
- voltage circuits of the EM are powered from power net and current circuits of the EM is powered from the TS33 – in this case the TS33 is used as a test system with reference meter and integrated current source in manual or automatic operation mode with predefined (current) load points,
- voltage and current circuits of the EM are powered from the TS33 – in this case the TS33 is used as a test system with reference meter and integrated voltage and current source in manual or automatic operation mode with predefined (voltage and current) load points,

with using following functions:

- calculating meter error (partial errors, average error, standard deviation) directly in [%] with method of settings time of measurement or number of pulses,
- measuring energy for verification of meter counters directly in [%],
- maximum power measuring for testing of maximum power meters,
- ✓ for different kind of measuring powers P, P+, P-, Q, Q+, Q-, S, as well as for the first harmonic of these powers,
- ✓ with visualization in form of table or trend chart.

In manual operation mode additionally may be used innovation functions:

- ✓ automatic identification of meter constant,
- ✓ automatic determining time of measurement or number of pulses.

In automatic operation mode accuracy may be referenced to an internal reference of the TS33 or to an external reference meter.

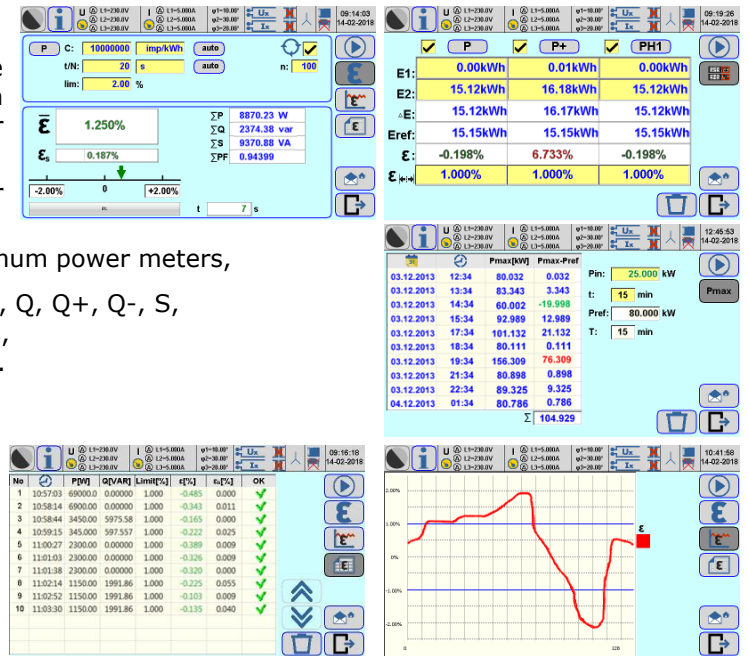

Specifications for impulse input/output				
Parameter	Voltage range	Frequency range	Resolution	Accuracy
Impulse Input for counting pulses (two inputs)	0...2V/4...30V	0.0001Hz...210kHz	0.0001%	0.001%@t≥1s
Impulse Output for Calmet TS33 testing	open collector 28V/100mA	0.0001Hz...210kHz	0.0001%	0.001%

Testing of instrument transformers - TT function (LV and MV current CT and potential PT simultaneously in three phases) directly on site:

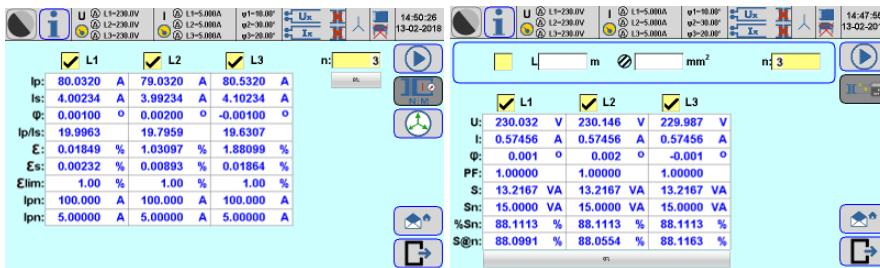

- function of calculating transformer ratio error directly in [%],
- function of calculating phase error,
- function of burden measurements of transformer.

Specifications for Burden measurement of PT and CT Transformers			
Parameter	Current range	Voltage range	Accuracy 1)2)
CT Burden	0.01...12A (Direct)	1...10V (Direct)	±0.2%
		0.05...1V (Direct)	±0.2%*
CT Burden	0.1...120A (Clamps CT100AC)	1...10V (Direct)	±0.4%
		0.05...1V (Direct)	±0.4%*
PT Burden	0.01...12A (Direct)	10...600V (Direct)	±0.1%
	0.001...0.01A (Direct)		±0.1%*
	0.1...12A (Clamps CT100AC)		±0.2%
Parameter	Primary current/voltage range	Secondary current/voltage range	Accuracy 1)2)3)
CT Ratio	0.2...120A (Clamps CT100AC)	0.1...12A (Clamps CT100AC)	±0.4%
		0.01...12A (Direct)	±0.2%
		0.001...0.01A (Direct)	±0.2%*
CT Ratio	10...1200A (Clamps CT1000AC)	0.1...12A (Clamps CT100AC)	±0.4%(clamps) / ±0.2%(direct)
CT Ratio	0.3...30A/3...300A/30...3000A (Flexible Clamps FCT3000AC.B)		0.01...12A (Direct)
CT Ratio	1...2000A (AmpLiteWire 2000A)		±0.1%±Em
PT Ratio	0.5...40kV (VoltLiteWire 40kV)	10...600V (Direct)	±0.1%±Em

1) % - related to the measuring value, %* - related to the measuring range final value (is underlined)
 2) absolute extended uncertainty under confidence level of 95% covers reference uncertainty of standards, stability in 12 months, influence quantities (ambient temperature +20...+26°C, humidity and power supply voltage 85...265V, frequency 47...63Hz)
 3) Em – sensor basic error, Em=1%+0.1%* (Flexible Clamps FCT3000AC.B), Em=2%+0.2%* (AmpLiteWire/VoltLiteWire sensors)

Data Management. The operator can store all measurements and test results on a modern SD memory card up to 32GB, for later visualization in LCD and printing directly from the TS33 using a wireless printer without the need of an external PC and putting the SD card.

The data management software TS33 PC Soft provides the ability to transfer the data between TS33 and an external PC. All results can be summarized and printed in a test report by putting the SD card into an external PC or downloaded through USB, Bluetooth or Ethernet.

The TS33 PC Soft software additionally provides the ability to manage data on an external PC or tablet:

- downloading of measurement results from the TS33 to a PC through communication port,
- archiving of measurement results and combining individual results into one collective file,
- printing of measurement results in a test reports,
- export of measurement results to Excel (directly to the XLSX file) and to the Windows clipboard.
- testing devices and performing measurements directly from a PC or tablet,
- sending files and test procedures from the TS33 to a PC,
- simultaneous testing of a device and performing additional activities in separate program windows:
 - ✓ measurement of network parameters,
 - ✓ registration of trends for all measured network parameters,
 - ✓ measurements of harmonics and histograms (bar chart),
 - ✓ observation of oscilloscopes (waveform) and vector diagram,
 - ✓ creating and modifying automatic meter testing procedures.











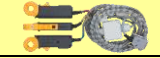
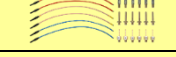

General parameters	
Weight and dimensions (width x height x depth)	22kg and (550x345x200) mm
Power supply	90...264V / 47...63Hz / 500VA
Safety: Isolation protection and Measurement Category	IEC 61010-1 and 300V CAT III
Degree of protection	IP-40 (housing open) / IP-67 (housing closed)
Operation / storage temperature	-10...+50°C / -20...+60°C
Operation / storage relative humidity	<90% @ +0...+30°C and <75% @ +30...+50°C / <95% @ 0...+50°C

Calmet TS33 Test System's equipment

All completed Calmet TS33 Test System's set consists of:

- Calmet TS33 test system class 0.02, 0.04 or 0.1,
- power cord,
- fuse T6A 250V (2pcs) and FF16A 500V (6pcs),
- memory card SD 8GB,
- EA36 set of safety measurement cables (12pcs),
- C091A T3475-001 plug Amphenol for Reference pulse output,
- operation manual,
- warranty card,
- calibration certificate.

Optionally for Calmet TS33 Test System are available:

• Calmet TS33 PC Soft with operation manual and USB B / USB A interface cable,		• CT10AC error compensated clamps up to 12A (3pcs),	
• TT function – Testing of CT and PT		• CT100AC error compensated clamps up to 120A (3pcs),	
• EA30 120A test leads (6pcs) with terminals set (18pcs),		• CT1000AC error compensated clamps up to 1200A (3pcs),	
• EA20 additional accessories for safety cables,		• FCT3000AC.B error compensated flexible clamps 30/300/3000A (3pcs),	
• CF106H photo head with holder for inductive meter and meter with LED,		• ALW2000AC.1 primary current sensor up to 2000A for LV and MV network (1pc),	
• DR200D miniature thermal printer with Bluetooth,		• VLW40kVC.1 primary voltage sensor up to 40kV (1pc),	
• ER10H.3 1-position rack for hanging of meter with quick connection device 3-phase,		• ET32 transportation case for additional accessories,	
		• Calmet TS33 option set 01 (Calmet TS33+ ET32+CT100AC+ CF106H+EA20).	

*) all images are for illustrative purposes only and are subject to change

Calmet sp. z o.o.

Kukulcza 18, 65-472 Zielona Gora, Poland

Phone +48 68 324 04 56 Fax +48 68 324 04 57

E-mail: mail@calmet.com.pl Web access: http://www.calmet.com.pl

Your sign

Date

Our sign

Date

CT/925/2023

2023-07-14

Manufacturer's Authorization Letter

WHEREAS we **CALMET Sp. z o.o.** who are official Manufacturer of Meter Testing Equipment, Meter Test Stations, Portable Meter Test Equipment and Accessories for testing and calibration, having factories at 65-472 Zielona Gora, ul. Kukulcza 18, Poland (European Union), tel.: +48 68 324 04 56 do hereby authorize:

Company: MV Corporation Ltd.,
ID: 206475290, Bulgaria, 1612 Sofia,
Lagera District, bl. 52, entr. G, fl.5

to represent us and give them the right to offer, deliver and service our production on the territory of Bulgaria.

We herewith guarantee the quality of our product.

This letter is valid until 31.12.2023.

CALMET sp. z o.o.
65-472 Zielona Góra, ul. Kukulcza 18
tel. +48 68 324 04 56, www.calmet.com.pl
NIP 929-10-19-640 REGON 970602765

Best regards,
Paweł Tarkowski

